

»FUTURA« series

Activated carbon filters in modern design for compliance with strict compressed air purity requirements. Activated carbon filters are used to absorb oil vapour up to a residual oil content of 0.005 mg/m³ from compressed air and gases.

Input pressure	0 - 16 bar
Temperature range	-10 °C to 50 °C
Medium	Compressed air, neutral gases
Housing	PA66 GF60
Connecting thread	Material: Die-cast zinc
Filter element	Activated carbon
Residual oil content	0.005 mg/m ³
Flow rate measurement	At P ₂ = 6 bar and pressure drop Δ _p = 0.2 bar

Activated carbon filter with metal bowl and sight glass

Art. No.	Type No.	Thread	Size	Flow rate l/min
156646	FU 891-M	G 1/4	1	470
156647	FU 892-M	G 3/8	1	470

Accessories / spare parts

Art. No.	Type No.	Description
100038	H 850	Mounting bracket, incl. 2 screws
100039	WK 100	Wall bracket, incl. 2 screws
100040	KP 100	Joiner set, incl. 2 screws
100197	BSA 14	Polycarbonate bowl, incl. bowl guard
100198	MA 14	Metal bowl, incl. sight glass
135851	WK 101-14	Wall bracket with connection thread G 1/4
135852	WK 101-38	Wall bracket with connection thread G 3/8
100199	A 23/70	Filter element (activated carbon-POM)

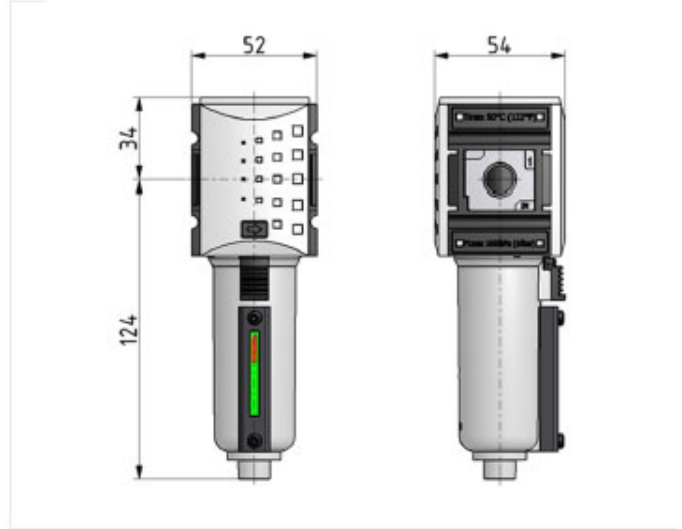

flow characteristic

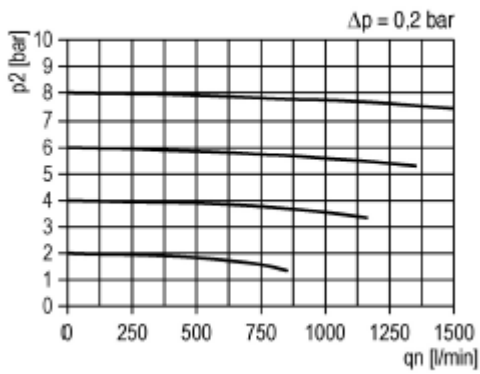

symbol

